

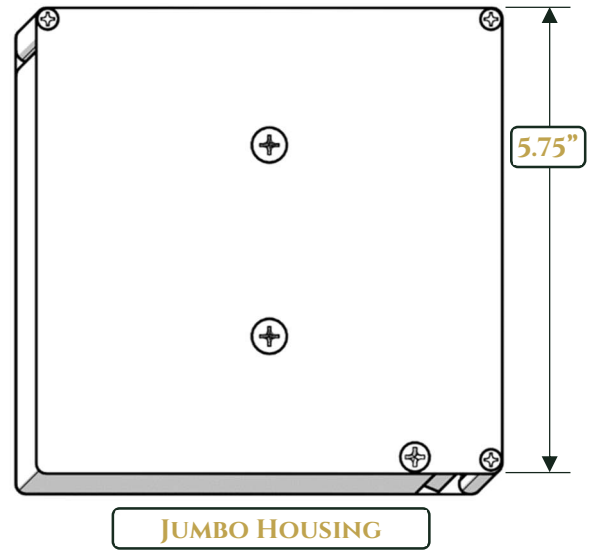

SECTION DETAILS

REV: 2022-01-06

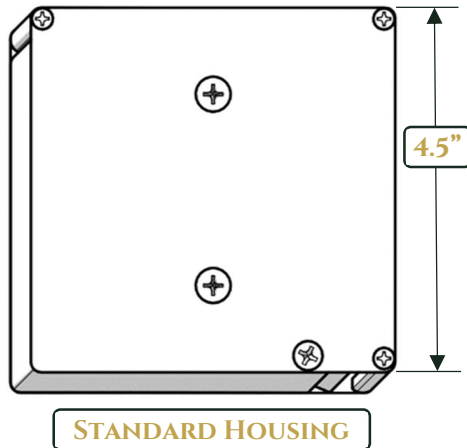
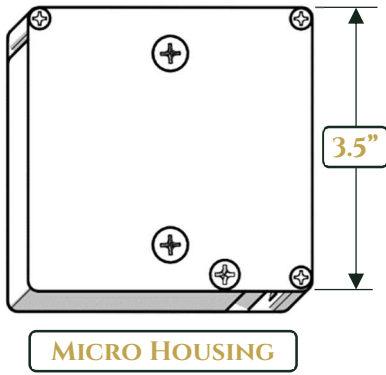

- FABRICATION INFO:**
- US MANUFACTURER
 - EACH UNIT CUSTOM MADE
 - AIRCRAFT GRADE ALUMINUM
 - PETG PLASTIC – FDM PRINTED
 - PVC FLEXI-RETAINER
 - INDIVIDUALLY AUDITED POWDERCOAT FINISH
 - STAINLESS STEEL HARDWARE
 - NO SEWN FABRIC RETENTION

- DRIVE OPTIONS:**
- ALPHA MOTOR (7YR WTY)
 - SOMFY MOTOR (5YR WTY)
 - SOLAR DC MOTOR
 - SUN/WIND SENSORS
 - HOME AUTOMATION

- PILE BRUSH:**
- ¼" BLACK
 - ¼" WHITE
 - ¼" GREY
 - 1" BLACK

- ELECTRICAL INFO:**
FOR STD MOTOR (A30/16)
- AC 120V/60HZ/1.60A
 - CONSUMPTION: 186W
-

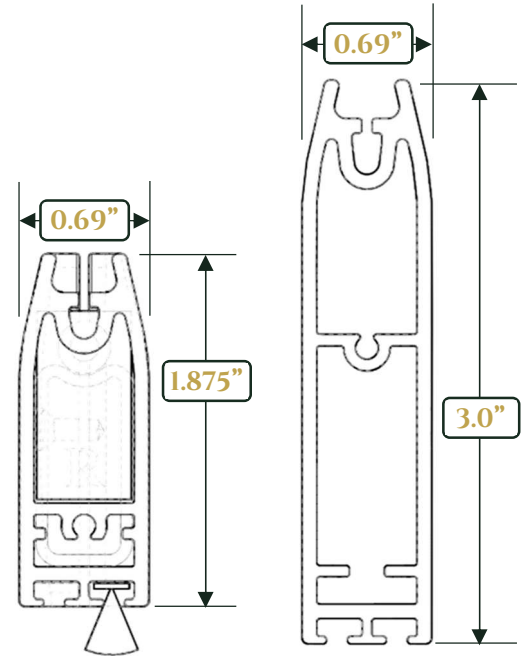
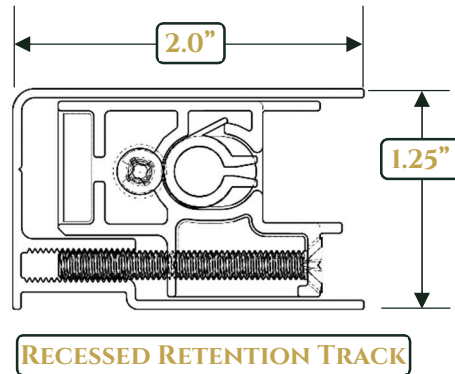
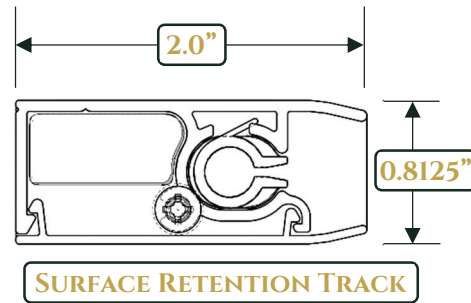

TEMPLAR STANDARD FRAME COLORS



HUNDREDS OF FABRIC OPTIONS AVAILABLE



And more...

